

## pE-100 Series Quick Start Guide



This guide should provide some basic information on the setup and operation of the CoolLED pE-100 Illumination System.

Before operating this product please read and observe the advice given in the safety section of the full User Manual.

For more detailed information on the full range of options and functions please see the full User Manual.

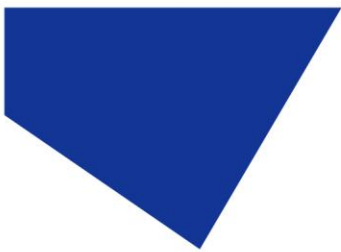

## 1. Contents



A typical pE-100 (direct fit) order will include the parts shown. A microscope adaptor that was specified when ordering will be fitted to the pE-100 Light Source. A mains power cable for the specified region of use shall also be included (not pictured).

If the liquid light guide version is being used then a specified light guide will be fitted.

The fibre version of the pE-100 is a fixed module that allows connection to any SMA terminated fibre. An appropriate fibre can be ordered through CoolLED if required.

## 2. Fitting the Light Source to a microscope

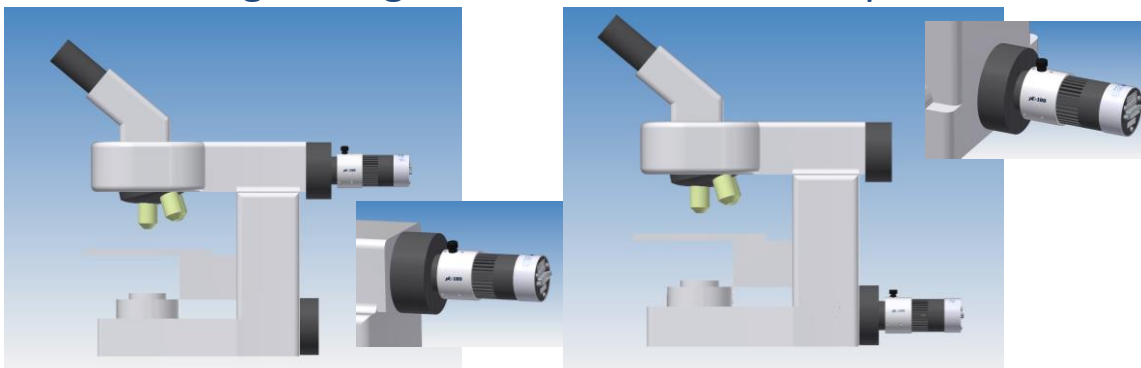

Epi-Fluorescent port

Transmitted (Brightfield) port

Attach the Light Source to the specified port of the microscope (Direct fit).

If using a liquid light guide version, attach to the microscope with appropriate collimating optics.

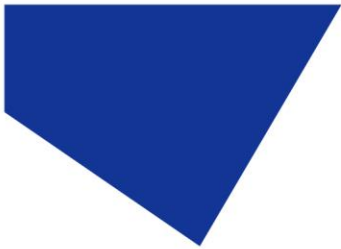

### 3. Connecting the Control Pod and power supply



Connect the Control Pod cable with the D-type connector to the Light Source.

Secure the connector in place with the screws, using a flat-headed screwdriver.



Insert the connector from the power supply into the Control Pod as shown.



Insert the mains lead connector into the power supply.

Insert the mains plug into an appropriate socket and switch on.

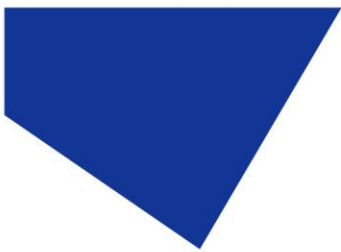

## 4. Control Pod operation

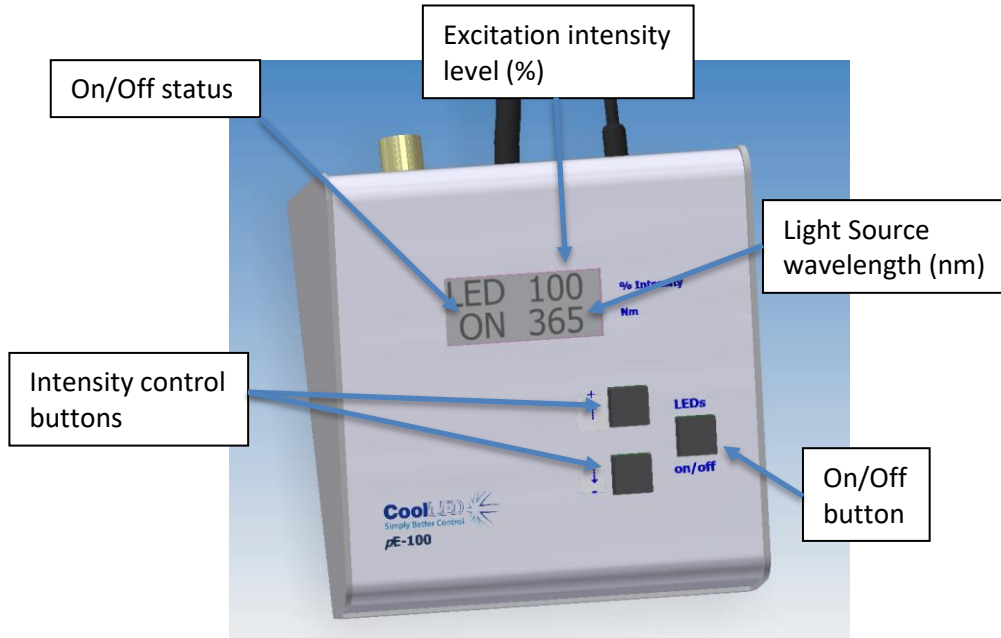

## 5. Optical adjustment (direct fit version)

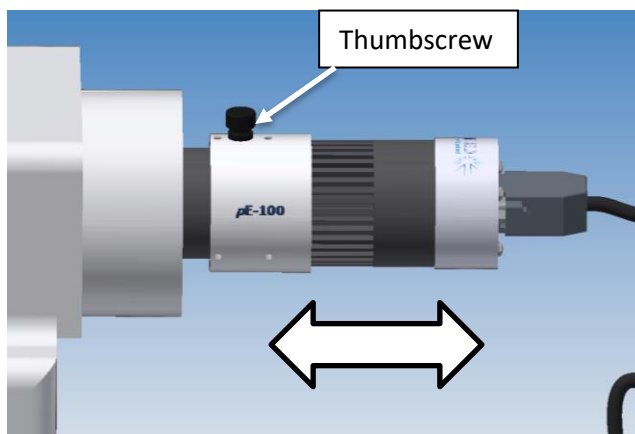

To optimize the Light Source set up a sample that covers the entire field of view.

Loosen the thumbscrew and slide the Light Source back and forth whilst viewing the sample.

Once you achieve maximum brightness with an even illumination secure the position by tightening the thumbscrew.

Example of the effect of the adjustment on the sample

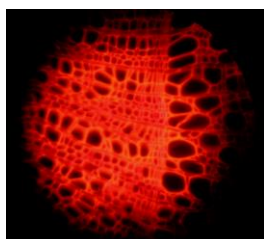

Light Source too far in

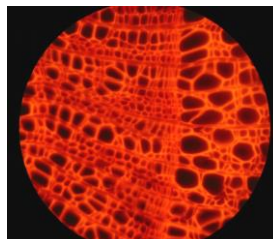

Light Source in optimal position

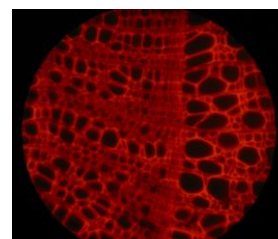

Light Source too far out